

SEL LINE

HIGH PRECISION BEARINGS FOR MACHINE TOOLS.

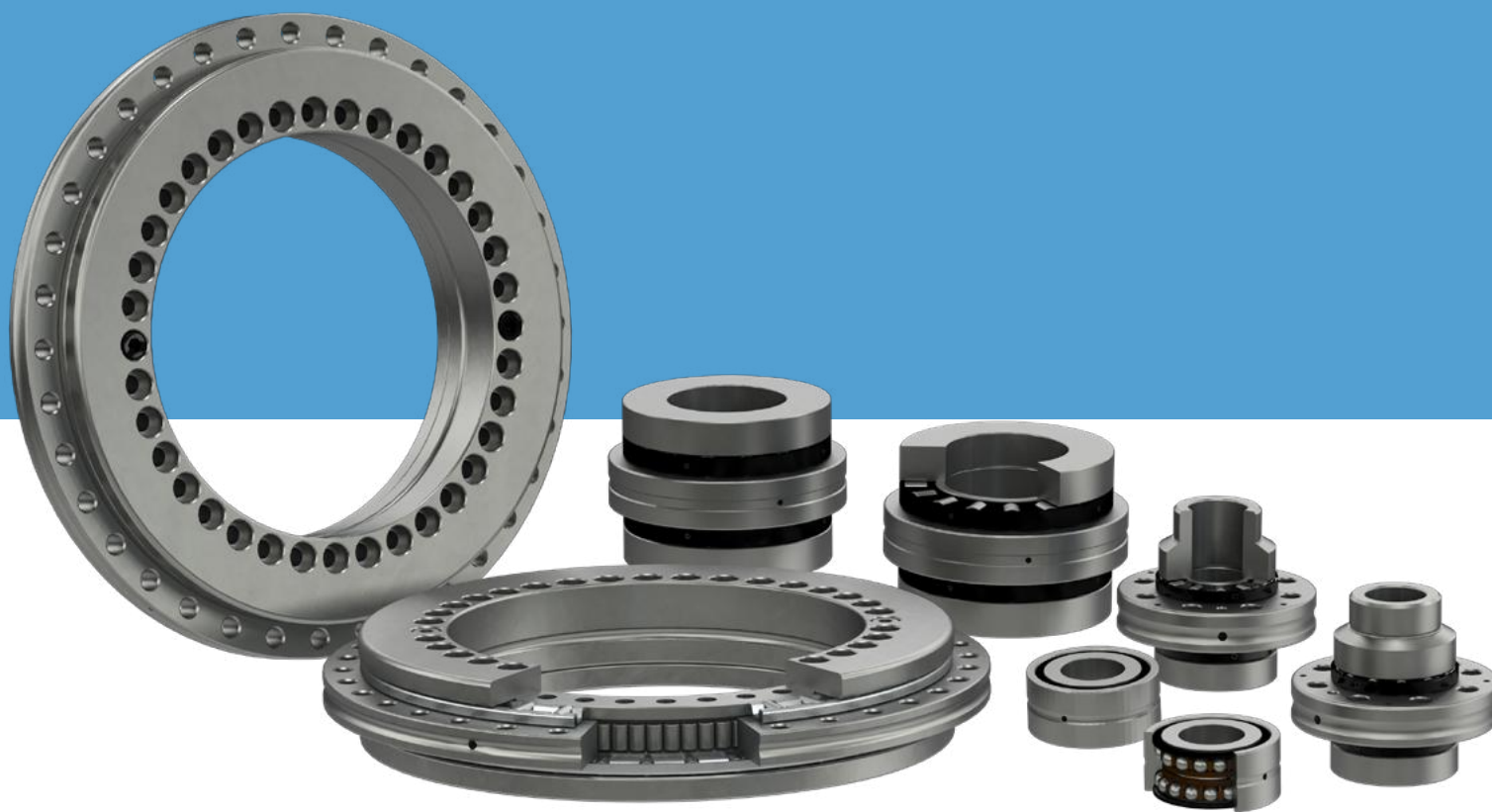

LIBE®
GRUPPI VOLVENTI



Contents

INTRODUCTION	4
--------------	---

 SEL/F	8
Angular contact ball bearing with holes for screw mounting.	

 SEL/N	10
Angular contact ball bearing.	

 SEL/Z	12
Combined cylindrical roller bearings, double axial direction and radial direction.	

 SEL/ZF	14
Combined cylindrical roller bearings, double axial direction and radial direction. Outer ring with holes for screw mounting.	

 SEL/ZFL	16
Combined cylindrical roller bearings, double axial direction and radial direction. Shaped extended washer. Outer ring with holes for screw mounting.	

 SEL/ZL	18
Combined cylindrical roller bearings, double axial direction and radial direction. With shaped extended washer.	

 SEL/Y	20
Axial/radial bearing - high running precision.	

 SEL/Y MK2	22
NEW VERSION: Axial/radial bearing - high running precision, high rigidity, high speed.	

 SEL/YAV	24
High Speed axial radial bearing - high running precision.	

TECHNICAL CONTENTS SEL/Y	26
--------------------------	----

TECHNICAL CONTENTS ROLLER BEARINGS FOR SCREW DRIVE	32
--	----

TECHNICAL CONTENTS BALL BEARINGS FOR SCREW DRIVE	34
--	----

INTRODUCTION



Founded in 1984, LI-BE produces special bearings, by dimension and execution, for different industrial applications.

The range of production includes bearings, rollers and complementary articles used in the sector of internal goods handling, metallurgical machinery, painting machinery, power transmission units, rotating tables for tool machines, etc.

LI-BE has always been synonymous with special bearings and is the holder of some international patents. For this reason the company uses a team of experts who are capable of providing solutions and projects which are suited to customers' specific requirements. Thanks to FEA and to the use of internal software we can have a more clear idea of the consequences of the loads on the bearings. A knowledge that, until a few years ago, was belonging to the most renowned manufacturers only.

Notwithstanding its hard-won position as market leader and aware of the rugged competition existing in its industry, LI-BE has never taken its attention off the niche market which are open to those companies that take flexibility, readiness, experience and reliability their strong points, as LI-BE does. Our know-how, the high quality of our products and the will to stand out in a more and more demanding industrial environment, make LI-BE the right partner for those who aim at high technological solutions.



FROM RAW MATERIAL

TO FINAL PRODUCT

SEL/F



It is a angular contact ball bearing of high precision that can bear axial forces from both directions and radial forces too. It has to be preloaded by means of a locknut. Its high precision makes it suitable for screw mounting. The outer ring has holes to allow screw mounting.

Available executions:

- ...2RS (lip seals on both sides)
- ...ZZ (gap seals on both sides)
- ...2RS PE (increased tolerances, lip seals on both sides)
- ...2RS 2AP (matched pair, lip seals on both sides)

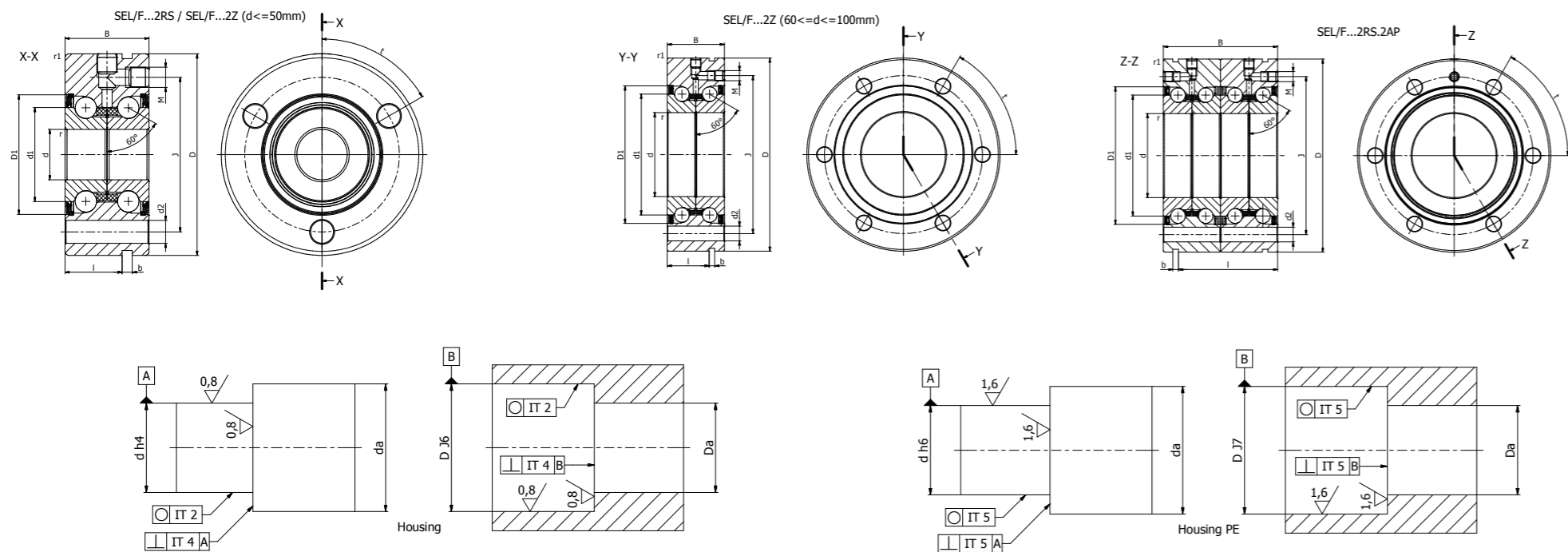

Code	MOUNTING DIMENSIONS					WEIGHT Kg	AXIAL LOAD		LIM. SPEED		DIMENSIONS							PITCH		FIXING		
	d	D	B	Da	da		Dyn. [C]	Stat. [C]	ng	nt	d1	D1	r (min)	r1	J	d2	b	l	Q.ty	t	Type	Q.ty
	mm	mm	mm	mm	mm		N	N	rpm	rpm	mm	mm	mm	mm	mm	mm	mm	mm	#	°		
SEL/F012055.2RS	12	55	25	33	16	0,37	16900	24700	3800	9200	25	32,6	0,3	0,6	42	6,5	3	17	3	120	M6	3
SEL/F012055.ZZ	12	55	25	33	16	0,37	16900	24700	7600	12000	25	32,6	0,3	0,6	42	6,5	3	17	3	120	M6	3
SEL/F012055.2RSPE	12	55	25	33	16	0,37	16900	24700	3800	9200	25	32,6	0,3	0,6	42	6,8	3	17	3	120	M6	3
SEL/F015060.2RS	12	60	25	35	20	0,43	17900	28000	3500	8200	28	35,6	0,3	0,6	46	6,5	3	17	3	120	M6	3
SEL/F015060.ZZ	15	60	25	35	20	0,43	17900	28000	7000	10800	28	35,6	0,3	0,6	46	6,5	3	17	3	120	M6	3
SEL/F015060.2RSPE	15	60	25	35	20	0,43	17900	28000	3500	8200	28	35,6	0,3	0,6	46	6,8	3	17	3	120	M6	3
SEL/F017062.2RS	17	62	25	37	23	0,45	18800	31000	3300	7600	30	37,9	0,3	0,6	48	6,5	3	17	3	120	M6	3
SEL/F017062.ZZ	17	62	25	37	23	0,45	18800	31000	6600	10100	30	37,9	0,3	0,6	48	6,5	3	17	3	120	M6	3
SEL/F017062.2RS2AP	17	62	50	37	23	0,9	30500	62000	3300	7600	30	37,9	0,3	0,6	48	6,5	3	42	6	60	M6	5
SEL/F017062.2RSPE	17	62	25	37	23	0,45	18800	31000	3300	7600	30	37,9	0,3	0,6	48	6,8	3	17	3	120	M6	3
SEL/F020068.2RS	20	68	28	43	25	0,61	26000	47000	3000	6600	34,5	42,5	0,3	0,6	53	6,5	3	19	4	90	M6	4
SEL/F020068.ZZ	20	68	28	43	25	0,61	26000	47000	5400	8700	34,5	42,5	0,3	0,6	53	6,5	3	19	4	90	M6	4
SEL/F020068.2RS2AP	20	68	56	43	25	1,22	42000	94000	3000	6600	34,5	42,5	0,3	0,6	53	6,5	3	47	8	45	M6	7
SEL/F020068.2RSPE	20	68	28	43	25	0,61	26000	47000	3000	6600	34,5	42,5	0,3	0,6	53	6,8	3	19	4	90	M6	4
SEL/F025075.2RS	25	75	28	48	32	0,72	27500	55000	2600	5700	40,5	48,6	0,3	0,6	58	6,5	3	19	4	90	M6	4
SEL/F025075.ZZ	25	75	28	48	32	0,72	27500	55000	4700	7500	40,5	48,6	0,3	0,6	58	6,5	3	19	4	90	M6	4
SEL/F025075.2RS2AP	25	75	56	48	32	1,44	44500	111000	2600	5700	40,5	48,6	0,3	0,6	58	6,5	3	47	8	45	M6	7
SEL/F025075.2RSPE	25	75	28	48	32	0,72	27500	55000	2600	5700	40,5	48,6	0,3	0,6	58	6,8	3	19	4	90	M6	4
SEL/F030080.2RS	30	80	28	53	40	0,78	29000	64000	2200	5000	45,5	54	0,3	0,6 v	63	6,5	3	19	6	60	M6	6
SEL/F030080.ZZ	30	80	28	53	40	0,78	29000	64000	4300	6700	45,5	54	0,3	0,6	63	6,5	3	19	6	60	M6	6
SEL/F030080.2RS2AP	30	80	56	53	40	1,56	47500	127000	2200	5000	45,5	54	0,3	0,6	63	6,5	3	47	12	30	M6	11
SEL/F030080.2RSPE	30	80	28	53	40	0,78	29000	64000	2200	5000	45,5	54	0,3	0,6	63	6,8	3	19	6	60	M6	6
SEL/F030100.2RS	30	100	38	64	47	1,63	65000	65000	2100	4500	51	78	0,3	0,3	0,6	8,8	3	30	8	45	M8	4
SEL/F030100.ZZ	30	100	38	64	47	1,63	65000	65000	4300	4600	51	78	0,3	0,3	0,6	8,8	3	30	8	45	M8	4
SEL/F035090.2RS	35	90	34	62	45	1,13	41000	89000	2000	4400	52	62,5	0,3	0,6	75	8,5	3	25	4	90	M8	4
SEL/F035090.ZZ	35	90	34	62	45	1,13	41000	89000	3800	5800	52	62,5	0,3	0,6	75	8,5	3	25	4	90	M8	4
SEL/F035090.2RS2AP	35	90	68	62	45	2,26	66000	177000	2000	4400	52	62,5	0,3	0,6	75	8,5	3	59	8	45	M8	7
SEL/F035090.2RSPE	35	90	34	62	45	1,13	41000	89000	2000	4400	52	62,5	0,3	0,6	75	8,8	3	25	4	90	M8	4
SEL/F040100.2RS	40	100	34	67	50	1,46	43000	101000	1800	4000	58	67,6	0,3	0,6	80	8,5	3	25	4	90	M8	4
SEL/F040100.ZZ	40	100	34	67	50	1,46	43000	101000	3300	5200	58	67,6	0,3	0,6	80	8,5	3	25	4	90	M8	4
SEL/F040100.2RS2AP	40	100	68	67	50	2,92	70000	202000	1800	4000	58	67,6	0,3	0,6	80	8,5	3	59	8	45	M8	7
SEL/F040100.2RSPE	40	100	34	67	50	1,46	43000	101000	1800	4000	58	67,6	0,3	0,6	80	8,8	3	25	4	90	M8	4
SEL/F040115.2RS	40	115	46	80	56	2,2	79000	149000	1600	3500	65	85	0,6	0,6	94	8,8	3	36	12	30	M8	12
SEL/F040115.ZZ	40	115	46	80	56	2,2	79000	149000	3100	4400	65	85	0,6	0,6	94	8,8	3	36	12	30	M8	12
SEL/F050115.2RS	50	115	34	82	63	1,86	46500	126000	1500	3200	72	81,8	0,3	0,6	94	8,5	3	25	6	60	M8	6
SEL/F050115.ZZ	50	115	34	82	63	1,86	46500	126000	3000	4200	72	81,8	0,3	0,6	94	8,5	3	25	6	60	M8	6
SEL/F050115.2RS2AP	50	115	68	82	63	3,72	76000	250000	1500	3200	72	81,8	0,3	0,6	94	8,5	3	59	12	30	M8	11
SEL/F050115.2RSPE	50	115	34	82	63	1,86	46500	126000	1500	3200	72	81,8	0,3	0,6	94	8,8	3	25	6	60	M8	6
SEL/F050140.2RS	50	140	54	98	63	4,7	125000	250000	1200	2900	80	92	0,6	0,6	113	11	3	45	12	30	M10	12
SEL/F050140.ZZ	50	140	54	98	63	4,7	125000	250000	2500	3500	80	92	0,6	0,6	113	11	3	45	12	30	M10	12
SEL/F060145.ZZ	60	145	45	100	82	4,3	84000	214000	3000	4000	85	99	0,6	0,6	120	8,5	3	35	8	45	M8	8
SEL/F070155.ZZ	70	155	45	110	92	4,9	88000	241000	2800	3800	95	109	0,6	0,6	130	9	3	35	8	45	M8	8
SEL/F080165.ZZ	80	165	45	120	102	5,3	91000	265000	2700	3600	105	119,8	0,6	0,6	140	8,5	3	35	8	45	M8	8
SEL/F090190.ZZ	90	190	55	138	116	8,7	135000	395000	2300	3500	120	137,2	0,6	0,6	165	10,5	3	45	8	45	M10	8
SEL/F100200.ZZ	100	200	55	150	128	9,3	140000	435000	2150	3300	132	150	0,6	0,6	175	10,5	3	45	8	45	M10	8
SEL/F100230.ZZ	100	230	85	175	130	17,6	295000	790000	2000	2900	146	170	0,6	0,6	200	14	3	73	12	30	M12	12



It is a angular contact ball bearing of high precision that can bear axial forces from both directions and radial forces too. It has to be preloaded by means of a locknut. Its high precision makes it suitable for screw mounting.

Available executions:

- ...2RS (lip seals on both sides)
- ...ZZ (gap seals on both sides)
- ...2RS PE (increased tolerances, lip seals on both sides)
- ...2RS 2AP (matched pair, lip seals on both sides)

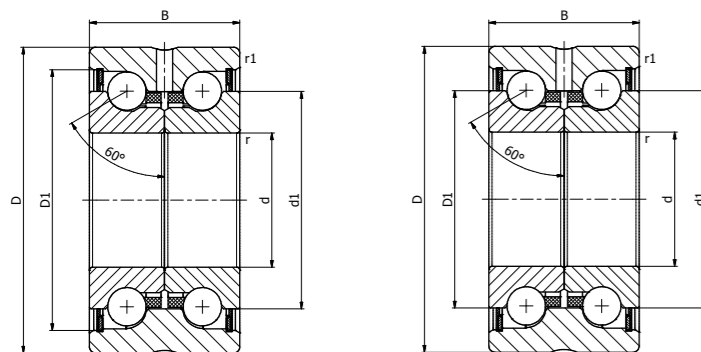

SEL/N...2RS / SEL/N...2RS.PE

SEL/N...ZZ

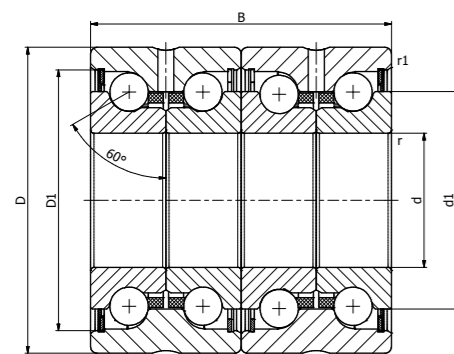

SEL/N...2RS.2AP

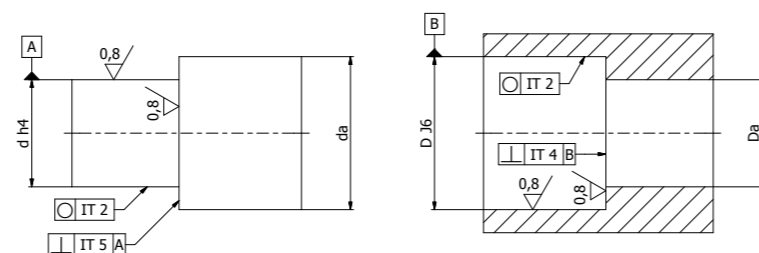

Housing

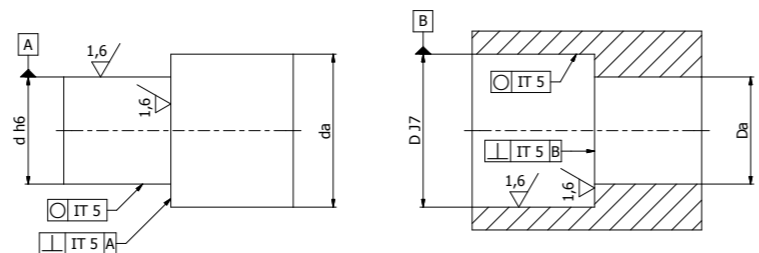

Housing PE

Code	MOUNTING DIMENSIONS					Kg	AXIAL LOAD		LIM. SPEED		DIMENSIONS			
	d	D	B	Da	da		Dyn. [C]	Stat. [C]	ng	nt	d1	D1	r (min)	r1 (min)
	mm	mm	mm	mm	mm		N	N	rpm	rpm	mm	mm	mm	mm
SEL/N012042.2RS	12	42	25	33	16	0,2	16900	24700	3800	9200	25	33,5	0,3	0,6
SEL/N012042.ZZ	12	42	25	33	16	0,2	16900	24700	7600	12000	25	33,5	0,3	0,6
SEL/N012042.2RSPE	12	42	25	33	16	0,2	16900	24700	3800	9200	25	33,5	0,3	0,6
SEL/N015045.2RS	15	45	25	35	20	0,21	17900	28000	3500	8200	28	36	0,3	0,6
SEL/N015045.ZZ	15	45	25	35	20	0,21	17900	28000	7000	10800	28	36	0,3	0,6
SEL/N015045.2RSPE	15	45	25	35	20	0,21	17900	28000	3500	8200	28	36	0,3	0,6
SEL/N017047.2RS	17	47	25	37	23	0,22	18800	31000	3300	7600	30	38	0,3	0,6
SEL/N017047.ZZ	17	47	25	37	23	0,22	18800	31000	6600	10100	30	38	0,3	0,6
SEL/N017047.2RS2AP	17	47	50	37	23	0,44	30500	62000	3300	7600	30	38	0,3	0,6
SEL/N017047.2RSPE	17	47	25	37	23	0,22	18800	31000	3300	7600	30	38	0,3	0,6
SEL/N020052.2RS	20	52	28	43	25	0,31	26000	47000	3000	6600	34,5	44	0,3	0,6
SEL/N020052.ZZ	20	52	28	43	25	0,31	26000	47000	5400	8700	34,5	44	0,3	0,6
SEL/N020052.2RS2AP	20	52	56	43	25	0,62	42000	94000	3000	6600	34,5	44	0,3	0,6
SEL/N020052.2RSPE	20	52	28	43	25	0,31	26000	47000	3000	6600	34,5	44	0,3	0,6
SEL/N025057.2RS	25	57	28	48	32	0,34	27500	55000	2600	5700	40,5	49	0,3	0,6
SEL/N025057.ZZ	25	57	28	48	32	0,34	27500	55000	4700	7500	40,5	49	0,3	0,6
SEL/N025057.2RS2AP	25	57	56	48	32	0,68	44500	111000	2600	5700	40,5	49	0,3	0,6
SEL/N025057.2RSPE	25	57	28	48	32	0,34	27500	55000	2600	5700	40,5	49	0,3	0,6
SEL/N030062.2RS	30	62	28	53	40	0,39	29000	64000	2200	5000	45,5	54	0,3	0,6
SEL/N030062.ZZ	30	62	28	53	40	0,39	29000	64000	4300	6700	45,5	54	0,3	0,6
SEL/N030062.2RS2AP	30	62	56	53	40	0,78	47500	127000	2200	5000	45,5	54	0,3	0,6
SEL/N030062.2RSPE	30	62	28	53	40	0,39	29000	64000	2200	5000	45,5	54	0,3	0,6
SEL/N030072.2RSPE	30	72	38	64	47	0,72	65000	108000	4500	2100	51	54	0,3	0,6
SEL/N030072.ZZ	30	72	38	64	47	0,72	65000	108000	5600	4000	51	54	0,3	0,6
SEL/N035072.2RS	35	72	34	62	45	0,51	41000	89000	2000	4400	52	63	0,3	0,6
SEL/N035072.ZZ	35	72	34	62	45	0,51	41000	89000	3800	5800	52	63	0,3	0,6
SEL/N035072.2RS2AP	35	72	68	62	45	1,02	66000	177000	2000	4400	52	63	0,3	0,6
SEL/N040075.2RS	40	75	34	67	50	0,61	43000	101000	1800	4000	58	68	0,3	0,6
SEL/N040075.ZZ	40	75	34	67	50	0,61	43000	101000	3300	5200	58	68	0,3	0,6
SEL/N040075.2RS2AP	40	75	68	67	50	1,22	70000	202000	1800	4000	58	68	0,3	0,6
SEL/N040090.2RS	40	90	46	80	56	0,95	65000	108000	2100	4500	65	75	0,6	0,6
SEL/N040090.ZZ	40	90	46	80	56	0,95	65000	108000	4000	5600	65	75	0,6	0,6
SEL/N050090.2RS	50	90	34	82	63	0,88	46500	126000	1500	3000	72	82	0,3	0,6
SEL/N050090.ZZ	50	90	34	82	63	0,88	46500	126000	3000	4200	72	82	0,3	0,6
SEL/N050110.2RS	50	110	54	98	63	2,5	125000	250000	1200	2900	80	102	0,6	0,6
SEL/N050110.ZZ	50	110	54	98	63	2,5	125000	250000	2500	3500	80	102	0,6	0,6
SEL/N050090.2RS2AP	50	90	68	82	63	1,76	76000	250000	1500	3000	72	82	0,3	0,6
SEL/N050090.2RSPE	50	90	34	82	63	0,88	46500	126000	1500	3000	72	82	0,3	0,6
SEL/N060110.ZZ	60	110	45	100	82	2,2	84000	214000	3000	4000	85	100	0,6	0,6
SEL/N070120.ZZ	70	120	45	110	92	2,4	88000	241000	2800	3800	95	110	0,6	0,6
SEL/N080130.ZZ	80	130	45	120	102	2,7	91000	265000	2700	3600	105	120	0,6	0,6
SEL/N090150.ZZ	90	150	55	138	116	4,5	135000	395000	2300	3500	120	138	0,6	0,6
SEL/N100160.ZZ	100	160	55	150	128	4,9	140000	435000	2150	3300	132	150	0,6	0,6



It is a combined bearing of high precision that can bear axial forces from both directions and radial forces too. Its high rigidity makes it suitable for screw mounting. It has to be preloaded by means of a locknut.

The bearing is made of a radial needle cage and of two axial roller cages. It can be relubricated both with oil and grease.

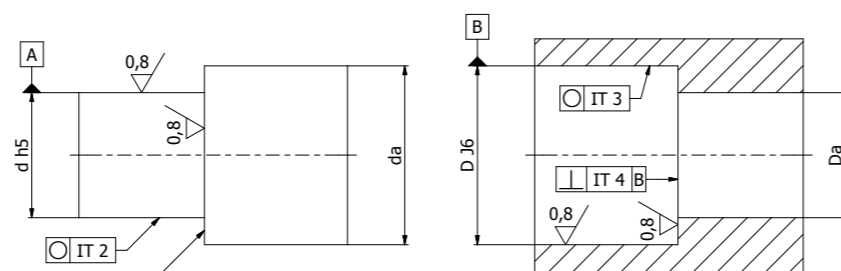
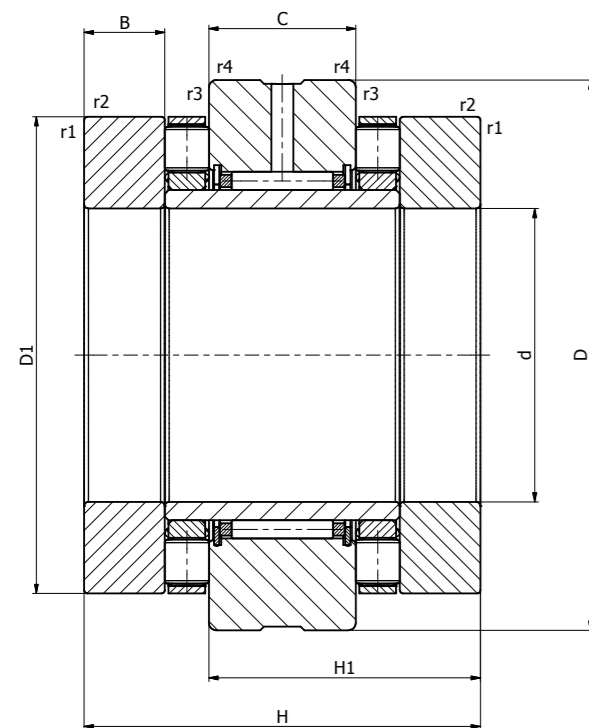

Housing

Code	OVERALL			RADIAL LOAD		AXIAL LOAD		LIM.SPEED		DIMENSIONS				
	d	D	H	Dyn. [C]	Stat. [C]	Dyn. [C]	Stat. [C]	Grease	Oil	B	C	H1	r1,2	r3,4
	mm	mm	mm	N	N	N	N	rpm	rpm	mm	mm	mm	mm	mm
SEL/Z015045	15	45	40	13000	17500	24900	53000	2200	8500	7,5	16	28	0,3	0,6
SEL/Z017047	17	47	43	14000	19900	26000	57000	2100	7800	9	16	29,5	0,3	0,6
SEL/Z020052	20	52	46	14900	22400	33500	76000	2000	7000	10	16	31	0,3	0,6
SEL/Z020062	20	62	60	22600	36000	64000	141000	1500	6000	12,5	20	40	0,3	0,6
SEL/Z025057	25	57	50	22600	36000	35500	86000	1900	6000	10	20	35	0,3	0,6
SEL/Z025072	25	72	60	24300	41500	80000	199000	1400	4900	12,5	20	40	0,3	0,6
SEL/Z030062	30	62	50	24300	41500	39000	101000	1800	5500	10	20	35	0,3	0,6
SEL/Z030080	30	80	66	26000	47000	107000	265000	1300	4400	14	20	43	0,3	0,6
SEL/Z035070	35	70	54	26000	47000	56000	148000	1700	4800	11	20	37	0,3	0,6
SEL/Z035085	35	85	66	27500	53000	105000	265000	1250	4000	14	20	43	0,3	0,6
SEL/Z040075	40	75	54	27500	53000	59000	163000	1600	4400	11	20	37	0,3	0,6
SEL/Z040090	40	90	75	38000	74000	117000	315000	1200	3700	16	25	50	0,3	0,6
SEL/Z045080	45	80	60	38000	74000	61000	177000	1500	4000	11,5	25	42,5	0,3	0,6
SEL/Z045105	45	105	82	40000	82000	154000	405000	1150	3300	17,5	25	53,5	0,3	0,6
SEL/Z050090	50	90	60	40000	82000	90000	300000	1200	3600	11,5	25	42,5	0,3	0,6
SEL/Z050110	50	110	82	42000	90000	172000	480000	1100	3100	17,5	25	53,5	0,3	0,6
SEL/Z055115	55	115	82	44000	98000	177000	500000	1000	2900	17,5	25	53,5	0,3	0,6
SEL/Z060120	60	120	82	44500	92000	187000	550000	950	2700	17,5	25	53,5	0,3	0,6
SEL/Z065125	65	125	82	54000	104000	172000	500000	900	2600	17,5	25	53,5	0,3	0,6
SEL/Z070130	70	130	82	56000	119000	201000	630000	800	2400	17,5	25	53,5	0,3	0,6
SEL/Z075155	75	155	100	72000	132000	290000	890000	700	2100	21	30	65	0,3	1

SEL/ZF



It is a combined bearing of high precision that can bear axial forces from both directions and radial forces too. Its high rigidity makes it suitable for screw mounting. It has to be preloaded by means of a locknut.

The bearing is made of a radial needle cage and of two axial roller cages.

It can be relubricated both with oil and grease.

The outer ring has holes to allow screw mounting.

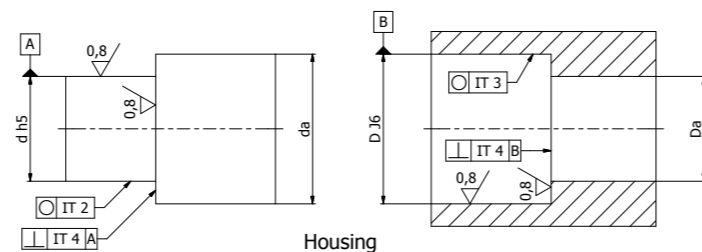
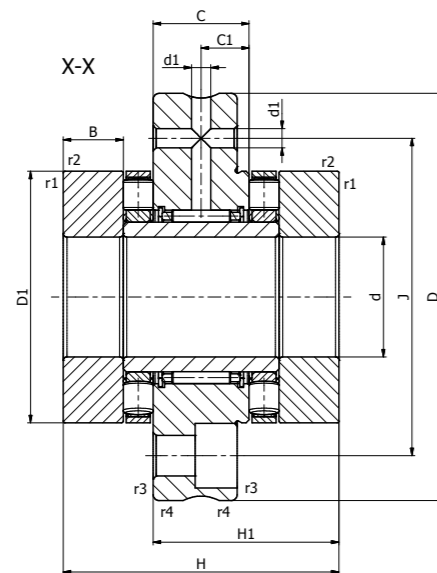
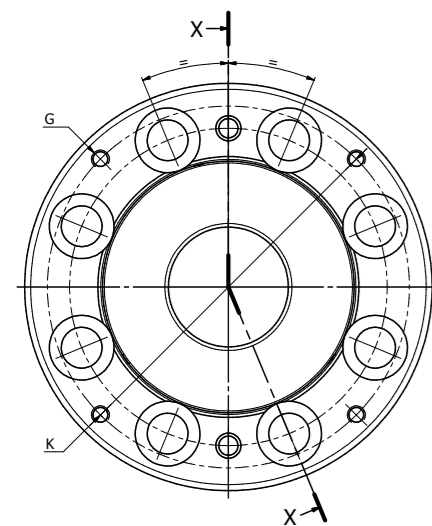

Code	OVERALL			AXIAL LOAD		RADIAL LOAD		LIMITING SPEED		DIMENSIONS									
	d	D	H	Dyn. [C]	Stat. [C]	Dyn. [C]	Stat. [C]	Grease	Oil	B	C	C1	H1	J	d1	r1,2	r3,4	K	G
	mm	mm	mm	N	N	N	N	rpm	rpm	mm	mm	mm	mm	mm	mm	mm	mm	mm	mm
SEL/ZF015060	15	60	40	24900	53000	13000	17500	2200	8500	7,5	14	8	26	46	3,2	0,3	0,6	52,4	M3
SEL/ZF017062	17	62	43	26000	57000	14000	19900	2100	7800	9	14	8	27,5	48	3,2	0,3	0,6	54,4	M3
SEL/ZF020068	20	68	46	33500	76000	14900	22400	2000	7000	10	14	8	29	53	3,2	0,3	0,6	60,4	M3
SEL/ZF020080	20	80	60	64000	141000	22600	36000	1500	6000	12,5	18	10	38	63	3,2	0,3	0,6	73,4	M3
SEL/ZF025075	25	75	50	35500	86000	22600	36000	1900	6000	10	18	10	33	58	3,2	0,3	0,6	67,4	M3
SEL/ZF025090	25	90	60	80000	199000	24300	41500	1400	4900	12,5	18	10	38	73	3,2	0,3	0,6	81	M3
SEL/ZF030080	30	80	50	39000	101000	24300	41500	1800	5500	10	18	10	33	63	3,2	0,3	0,6	73,4	M3
SEL/ZF030105	30	105	66	107000	265000	26000	47000	1300	4400	14	18	10	41	85	3,2	0,3	0,6	95	M4
SEL/ZF035090	35	90	54	56000	148000	26000	47000	1700	4800	11	18	10	35	73	3,2	0,3	0,6	80	M4
SEL/ZF035110	35	110	66	105000	265000	27500	53000	1250	4000	14	18	10	41	88	3,2	0,3	0,6	101	M3
SEL/ZF040100	40	100	54	59000	163000	27500	53000	1600	4400	11	18	10	35	80	3,2	0,3	0,6	90	M4
SEL/ZF040115	40	115	75	117000	315000	38000	74000	1200	3700	16	22,5	12,5	47,5	94	3,2	0,3	0,6	106	M3
SEL/ZF045105	45	105	60	61000	177000	38000	74000	1500	4000	11,5	22,5	12,5	40	85	6	0,3	0,6	95	M4
SEL/ZF045130	45	130	82	154000	405000	40000	82000	1150	3300	17,5	22,5	12,5	51	105	6	0,3	0,6	120	M4
SEL/ZF050115	50	115	60	90000	300000	40000	82000	1200	3600	11,5	22,5	12,5	40	94	6	0,3	0,6	106	M3
SEL/ZF050140	50	140	82	172000	480000	42000	90000	1100	3100	17,5	22,5	12,5	51	113	6	0,3	0,6	127,5	M5
SEL/ZF055145	55	145	82	177000	500000	44000	98000	1000	2900	17,5	22,5	12,5	51	118	6	0,3	0,6	132,5	M5
SEL/ZF060150	60	150	82	187000	550000	44500	92000	950	2700	17,5	22,5	12,5	51	123	6	0,3	0,6	137,5	M5
SEL/ZF065155	65	155	82	172000	500000	54000	104000	900	2600	17,5	22,5	12,5	51	128	6	0,3	0,6	142,5	M5
SEL/ZF070160	70	160	82	201000	630000	56000	119000	800	2400	17,5	22,5	12,5	51	133	6	0,3	0,6	147,5	M5
SEL/ZF075185	75	185	100	290000	890000	72000	132000	700	2100	21	27	15	62	155	6	0,3	1	172,5	M5
SEL/ZF090210	90	210	110	325000	1030000	98000	210000	700	1800	22,5	32	17,5	69,5	180	8	0,3	1	194	M5

SEL/ZFL



It is a combined bearing of high precision that can bear axial forces from both directions and radial forces too. Its high rigidity makes it suitable for screw mounting. It has to be preloaded by means of a locknut.

The bearing is made of a radial needle cage and of two axial roller cages.

It can be relubricated both with oil and grease.

The outer ring has holes to allow screw mounting.

Differently from series SEL/ZFL, this series shows a shaped and extended washer.

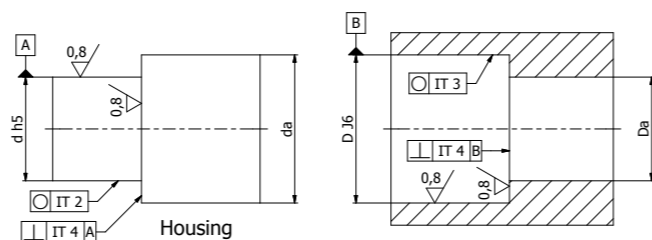
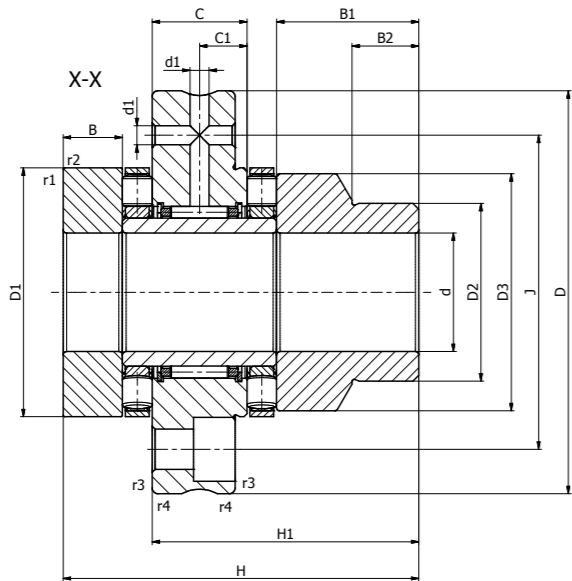
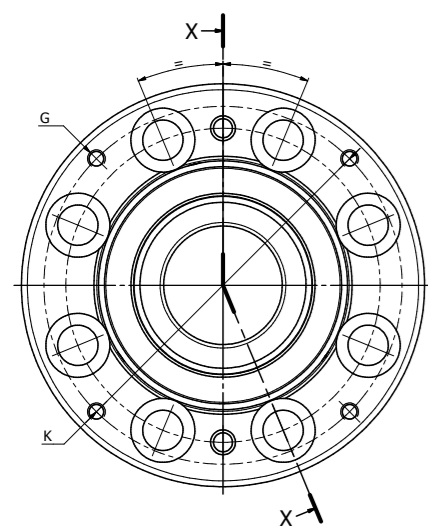

Code	OVERALL			AXIAL LOAD		RADIAL LOAD		LIMITING SPEED		DIMENSIONS														
	d	D	H	Dyn. [C]	Stat. [C]	Dyn. [C]	[Cu]	Grease	Oil	D2	D3	B	B1	B2	C	C1	H1	J	d1	r1,2	r3,4	K	G	
	mm	mm	mm	N	N	N	N	rpm	rpm	mm	mm	mm	mm	mm	mm	mm	mm	mm	mm	mm	mm	mm	mm	mm
SEL/ZFL015060	15	60	53	24900	53000	13000	17500	2200	8500	24	34	7,5	20,5	11	14	8	39	46	3,2	0,3	0,6	52,4	M3	
SEL/ZFL017062	17	62	57	26000	57000	14000	19900	2100	7800	28	38	9	23	11	14	8	41,5	48	3,2	0,3	0,6	54,4	M3	
SEL/ZFL020068	20	68	60	33500	76000	14900	22400	2000	7000	30	40	10	24	11	14	8	43	53	3,2	0,3	0,6	60,4	M3	
SEL/ZFL020080	20	80	75	64000	141000	22600	36000	1500	6000	40	50	12,5	27,5	11	18	10	53	63	3,2	0,3	0,6	73,4	M3	
SEL/ZFL025075	25	75	65	35500	86000	22600	36000	1900	6000	36	45	10	25	11	18	10	48	58	3,2	0,3	0,6	67,4	M3	
SEL/ZFL025090	25	90	75	80000	199000	24300	41500	1400	4900	48	60	12,5	27,5	11	18	10	53	73	3,2	0,3	0,6	81	M3	
SEL/ZFL030080	30	80	65	39000	101000	24300	41500	1800	5500	40	50	10	25	11	18	10	48	63	3,2	0,3	0,6	73,4	M3	
SEL/ZFL030105	30	105	82	107000	265000	26000	47000	1300	4400	52	66	14	30	12	18	10	57	85	3,2	0,3	0,6	95	M4	
SEL/ZFL035090	35	90	70	56000	148000	26000	47000	1700	4800	45	58	11	27	12	18	10	51	73	3,2	0,3	0,6	80	M4	
SEL/ZFL035110	35	110	82	105000	265000	27500	53000	1250	4000	60	73	14	30	12	18	10	57	88	3,2	0,3	0,6	101	M3	
SEL/ZFL040100	40	100	70	59000	163000	27500	53000	1600	4400	50	63	11	27	12	18	10	51	80	3,2	0,3	0,6	90	M4	
SEL/ZFL040115	40	115	93	117000	315000	38000	74000	1200	3700	60	78	16	34	12	22,5	12,5	65,5	94	6	0,3	0,6	106	M3	
SEL/ZFL045105	45	105	75	61000	177000	38000	74000	1500	4000	56	68	11,5	26,5	12	22,5	12,5	55	85	6	0,3	0,6	95	M4	
SEL/ZFL045130	45	130	103	154000	405000	40000	82000	1150	3300	70	88	17,5	38,5	14	22,5	12,5	72	105	6	0,3	0,6	120	M4	
SEL/ZFL050115	50	115	78	90000	300000	40000	82000	1200	3600	60	78	11,5	29,5	12	22,5	12,5	58	94	6	0,3	0,6	106	M3	
SEL/ZFL050140	50	140	103	172000	480000	42000	90000	1100	3100	75	93	17,5	38,5	14	22,5	12,5	72	113	6	0,3	0,6	124,5	M5	
SEL/ZFL055145	55	145	103	177000	500000	44000	98000	1000	2900	80	98	17,5	38,5	14	22,5	12,5	72	118	6	0,3	0,6	132,5	M5	
SEL/ZFL060150	60	150	103	187000	550000	44500	92000	950	2700	90	105	17,5	38,5	16	22,5	12,5	72	123	6	0,3	0,6	137,5	M5	
SEL/ZFL065155	65	155	103	172000	500000	54000	104000	900	2600	90	108	17,5	38,5	16	22,5	12,5	72	128	6	0,3	0,6	142,5	M5	
SEL/ZFL070160	70	160	103	201000	630000	56000	119000	800	2400	100	115	17,5	38,5	16	22,5	12,5	72	133	6	0,3	0,6	147,5	M5	
SEL/ZFL075185	75	185	125	290000	890000	72000	132000	700	2100	115	135	21	46	16	27	15	87	155	6	0,3	1	172,5	M5	
SEL/ZFL090210	90	210	135	325000	1030000	98000	210000	700	1800	130	158	22,5	47,5	16	32	17,5	94,5	180	8	0,3	1	194	M5	

SEL/ZL



It is a combined bearing of high precision that can bear axial forces from both directions and radial forces too. Its high rigidity makes it suitable for screw mounting. It has to be preloaded by means of a locknut.

The bearing is made of a radial needle cage and of two axial roller cages.

It can be relubricated both with oil and grease.

Differently from series SEL/Z, this series shows a shaped and extended washer.

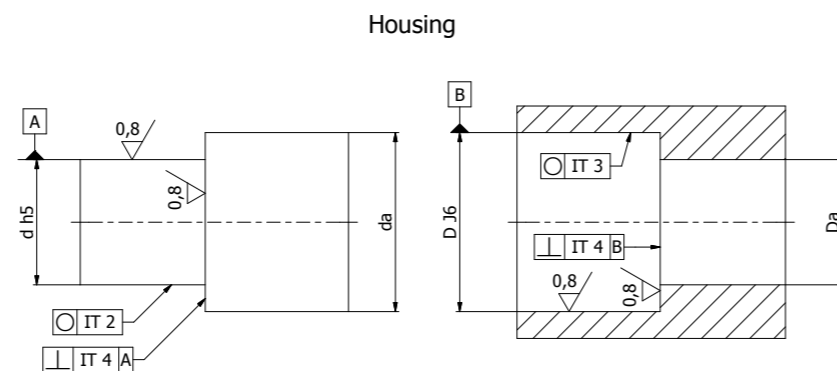
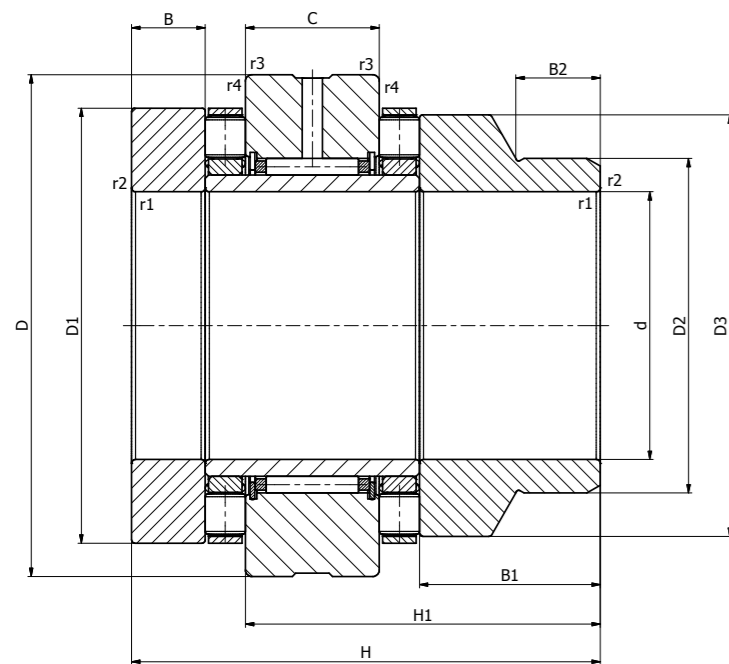

Code	OVERALL DIMEN-			RADIAL LOAD		AXIAL LOAD RAT-		LIMITING		DIMENSIONS								
	d	D	H	Dyn. [C]	Stat. [C]	Dyn. [C]	Stat. [C]		Oil	D2	D3	B	B1	B2	C	H1	r1,2	r3,4
	mm	mm	mm	N	N	N	N	rpm	rpm	mm	mm	mm	mm	mm	mm	mm	mm	mm
SEL/ZL015045	15	45	53	13000	17500	24900	53000	2200	8500	24	34	7,5	20,5	11	16	41	0,3	0,6
SEL/ZL017047	17	47	57	14000	19900	26000	57000	2100	7800	28	38	9	23	11	16	43,5	0,3	0,6
SEL/ZL020052	20	52	60	14900	22400	35500	76000	2000	7000	30	40	10	24	11	16	45	0,3	0,6
SEL/ZL020062	20	62	75	22600	36000	64000	141000	1500	6000	40	50	12,5	27,5	11	20	55	0,3	0,6
SEL/ZL025057	25	57	65	22600	36000	33500	86000	1900	6000	36	45	10	25	11	20	50	0,3	0,6
SEL/ZL025072	25	72	75	24300	41500	80000	199000	1400	4900	48	60	12,5	27,5	11	20	55	0,3	0,6
SEL/ZL030062	30	62	65	24300	41500	39000	101000	1800	5500	40	50	10	25	11	20	50	0,3	0,6
SEL/ZL030080	30	80	82	26000	47000	107000	265000	1300	4400	52	66	14	30	12	20	59	0,3	0,6
SEL/ZL035070	35	70	70	26000	47000	56000	148000	1700	4800	45	58	11	27	12	20	53	0,3	0,6
SEL/ZL035085	35	85	82	27500	53000	105000	265000	1250	4000	60	73	14	30	12	20	59	0,3	0,6
SEL/ZL040075	40	75	70	27500	53000	59000	163000	1600	4400	50	63	11	27	12	20	53	0,3	0,6
SEL/ZL040090	40	90	93	38000	74000	117000	315000	1200	3700	60	78	16	34	12	25	68	0,3	0,6
SEL/ZL045080	45	80	75	38000	74000	61000	177000	1500	4000	56	68	11,5	26,5	12	25	57,5	0,3	0,6
SEL/ZL045105	45	105	103	40000	82000	154000	405000	1150	3300	70	88	17,5	38,5	14	25	74,5	0,3	0,6
SEL/ZL050090	50	90	78	40000	82000	90000	300000	1200	3600	60	78	11,5	29,5	12	25	60,5	0,3	0,6
SEL/ZL050110	50	110	103	42000	90000	172000	480000	1100	3100	75	93	17,5	38,5	14	25	74,5	0,3	0,6
SEL/ZL055115	55	115	103	44000	98000	177000	500000	1000	2900	80	98	17,5	38,5	14	25	74,5	0,3	0,6
SEL/ZL060120	60	120	103	44500	92000	187000	550000	950	2700	90	105	17,5	38,5	16	25	74,5	0,3	0,6
SEL/ZL065125	65	125	103	54000	104000	172000	500000	900	2600	90	108	17,5	38,5	16	25	74,5	0,3	0,6
SEL/ZL070130	70	130	103	56000	119000	201000	630000	800	2400	100	115	17,5	38,5	16	25	74,5	0,3	0,6
SEL/ZL075155	75	155	125	72000	132000	290000	890000	700	2100	115	135	21	46	16	30	90	0,3	1
SEL/ZL090180	90	180	135	98000	210000	325000	1030000	700	1800	130	158	22,5	47,5	16	35	97,5	0,3	1



The main characteristics of this type of combined bearing are: high running precision, high rigidity at tilting moments and high carrying capacities. These features together with the wide dimensional range make this bearing the right solution for rotary tables, swivel heads, measuring instruments and automation systems.

The bearing is made of two axial needle cage assemblies while the radial part is full complement. The washer, the inner ring and the outer ring have holes to allow mounting by screws. These bearings can be relubricated through the inner ring and the outer ring. They are supplied with grease lubrication.

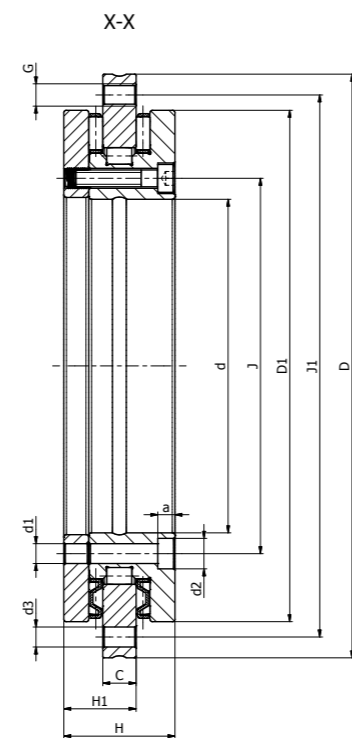
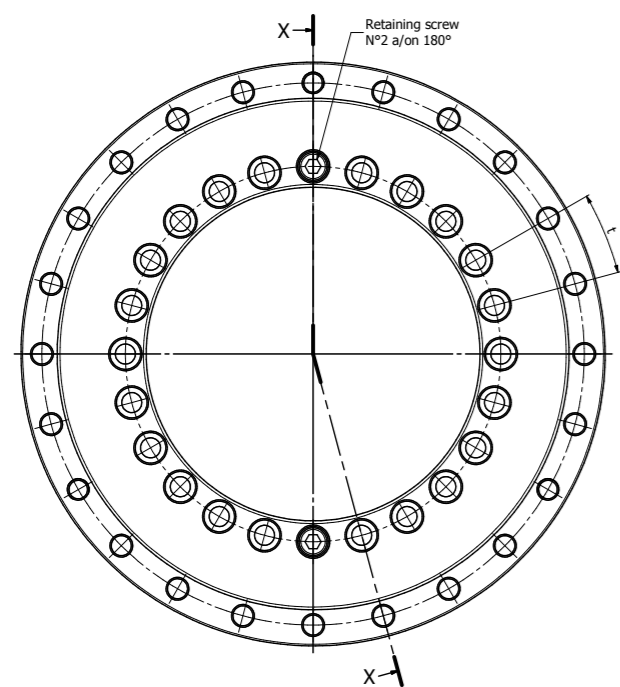

Code	DIMENSIONS								FIXING HOLES Inner				FIXING			PITCH				AXIAL LOAD			RADIAL LOAD		
	d	D	H	H1	C	D1	J	J1	d1	d2	a	Q.ty.	d3	Q.ty.	Q.ty.	Q.ty.	t	Q.ty.		Ma	Dyn. [C]	Stat. [C]	Dyn. [C]	Stat. [C]	ng
	mm	mm	mm	mm	mm	mm	mm	mm	mm	mm	mm	#	mm	#	#	#	°	#	Kg	Nm	N	N	N	N	rpm
SEL/Y050	50	126	30	20	10	105	63	116	5,6	0	0	10	5,6	12	2	12	30	0	16	9	56000	280000	28500	49500	440
SEL/Y080	80	146	35	23,4	12	130	92	138	5,6	10	4	10	4,6	12	2	12	30	0	24	5	38000	158000	44000	98000	350
SEL/Y100	100	185	38	25	12	161	112	170	5,6	10	5,4	16	5,6	15	2	18	20	3	41	9	73000	370000	52000	108000	280
SEL/Y120	120	210	40	26	12	185	135	195	7	11	6,2	22	7	21	2	24	15	3	53	14	80000	445000	70000	148000	230
SEL/Y150	150	240	40	26	12	214	165	225	7	11	6,2	34	7	33	2	36	10	3	62	14	85000	510000	77000	179000	210
SEL/Y180	180	280	43	29	15	244	194	260	7	11	6,2	46	7	45	2	48	7,5	3	77	14	92000	580000	83000	209000	190
SEL/Y200	200	300	45	30	15	274	215	285	7	11	6,2	46	7	45	2	48	7,5	3	97	14	98000	650000	89000	236000	170
SEL/Y260	260	385	55	36,5	18	345	280	365	9,3	15	8,2	34	9,3	33	2	36	10	3	183	34	109000	810000	102000	310000	130
SEL/Y325	325	450	60	40	20	415	342	430	9,3	15	8,2	34	9,3	33	2	36	10	3	250	34	186000	1710000	134000	415000	110
SEL/Y395	395	525	65	42,5	20	486	415	505	9,3	15	8,2	46	9,3	45	2	48	7,5	3	330	34	202000	2010000	133000	435000	90
SEL/Y460	460	600	70	46	22	560	482	580	9,3	15	8,2	46	9,3	45	2	48	7,5	3	450	34	217000	2300000	187000	650000	80
SEL/Y580	580	750	90	60	30	700	610	720	11,4	18	11	46	11,4	42	2	48	7,5	6	890	68	390000	3600000	211000	820000	80
SEL/Y650	650	870	122	78	34	800	680	830	14	20	13	46	14	42	2	48	7,5	6	170	116	495000	5200000	415000	1500000	70
SEL/Y850	850	1095	124	80,5	37	1018	890	1060	18	26	17	58	18	54	2	60	6	6	253	284	560000	6600000	475000	1970000	50
SEL/Y950	950	1200	132	86	40	1130	990	1060	18	26	17	58	18	54	2	60	6	6	312	284	1040000	10300000	600000	2450000	40

SEL/Y MK2

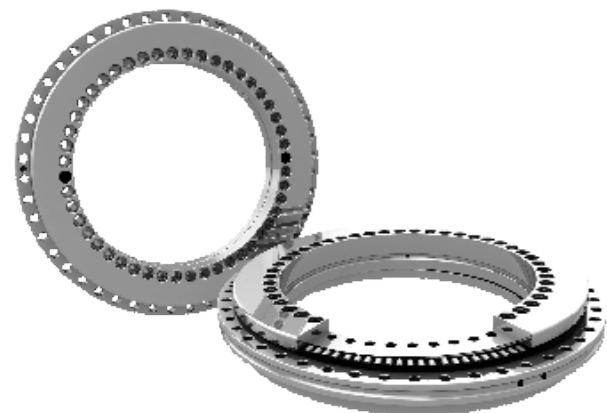

SEL/Y.MKII represent the evolution of our well known SEL/Y.

It comes with higher performances but with the same mounting dimensions: you don't need to modify your rotary table designs, since SEL/Y.MKII is totally interchangeable with the old SEL/Y.

The bearing is made of two axial needle cage assemblies while the radial part is full complement.

The washer, the inner ring and the outer ring have holes to allow mounting by screws. These bearings can be relubricated through the inner ring and the outer ring.

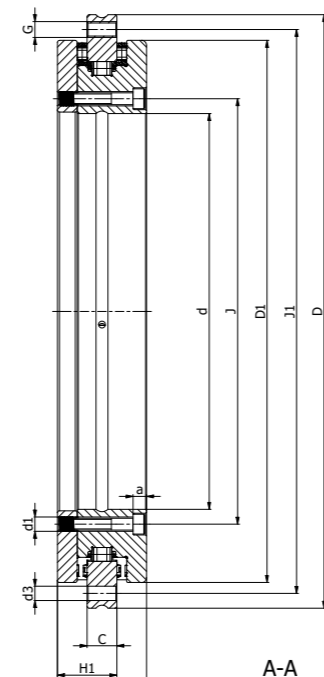
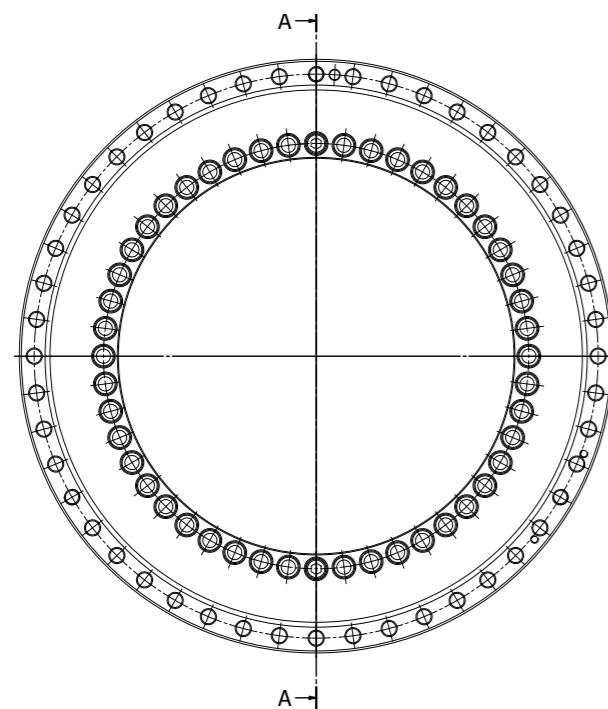

Code	DIMENSIONS								FIXING HOLES Inner				FIXING		PITCH				AXIAL LOAD RATING		RADIAL LOAD RATING		ng		
	d	D	H	H1	C	D1	J	J1	d1	d2	a	Q.ty.ir	d3	Q.ty	Q.ty.	Q.ty.	t	Q.ty.	Ma	Dyn. [C]	Stat. [C]	Dyn. [C]		Stat. [C]	rpm
	mm	mm	mm	mm	mm	mm	mm	mm	mm	mm	mm	#	mm	#	#	#	°	#	Kg	Nm	N	N	N	N	
SEL/Y0100.MK2	100	185	38	25	12	161	112	170	5,6	10	5,4	16	5,6	15	2	18	20	3	3,62	8,5	105.000	455.000	49.500	88.000	1200
SEL/Y0120.MK2	120	210	40	26	12	185	135	195	7	11	6,2	22	7	21	2	24	15	3	4,56	14	112.000	520.000	69.000	124.000	900
SELY/0150.MK2	150	240	40	26	12	214,5	165	225	7	11	6,2	34	7	33	2	36	10	3	5,3	14	128.000	650.000	74.000	146.000	800
SELY/0180.MK2	180	280	43	29	15	245,1	194	260	7	11	6,2	46	7	45	2	48	7,5	3	7,1	14	134.000	730.000	100.000	200.000	600
SELY/0200.MK2	200	300	45	30	15	274,4	215	285	7	11	6,2	46	7	45	2	48	7,5	3	9,149	14	147.000	850.000	123.000	275.000	450
SELY/0260.MK2	260	385	55	36,5	18	347	280	365	9,3	15	8,2	34	9,3	33	2	36	10	3	17,8	34	168.000	1.090.000	140.000	355.000	300
SELY/0325.MK2	325	450	60	40	20	415,1	342	430	9,3	15	8,2	34	9,3	33	2	36	10	3	24,675	34	247.000	1.900.000	183.000	530.000	200
SELY/0395.MK2	395	525	65	42,5	20	487,7	415	505	9,3	15	8,2	46	9,3	45	2	48	7,5	3	32,5	34	265.000	2.190.000	200.000	640.000	200
SELY/0460.MK2	460	600	70	46	22	560,9	482	580	9,3	15	8,2	46	9,3	45	2	48	7,5	3	45,1	34	290.000	2.550.000	265.000	880.000	150
SELY/0580.MK2	580	750	90	60	30	700	610	720	11,4	18	11	46	11,4	42	2	48	7,5	6	85,2	68	580.000	4.450.000	235.000	730.000	80
SELY/0650.MK2	650	870	122	78	34	800	680	830	14	20	13	46	14	42	2	48	7,5	6	165	116	910.000	6.800.000	455.000	1.300.000	70
SELY/0850.MK2	850	1095	124	80,5	37	1018	890	1055	18	26	17	58	18	54	2	60	6	6	245,12	284	1.020.000	8.500.000	520.000	1.690.000	50

PLEASE NOTE: the bearings technical performances are still under analysis. Please contact LI-BE for the latest data available.

SEL/YAV



Such as standard version SEL/Y, combined bearing SEL/YAV is characterized by high running precision, high rigidity at tilting moments and high carrying capacities. Over these features, that make this bearing the right solution for rotary tables, swivel heads, measuring instruments and automation systems, SEL/YAV is able to reach high rotational speed. Thanks to its internal geometry, SEL/YAV can reach high rotational speed without any losses in terms of run-out or rigidity. The bearing is made of two axial roller cage assemblies and one radial roller cage assembly. The washer, the inner ring and the outer ring have holes to allow mounting by screws. These bearings can be relubricated through the inner ring and the outer ring. They are supplied with grease lubrication.

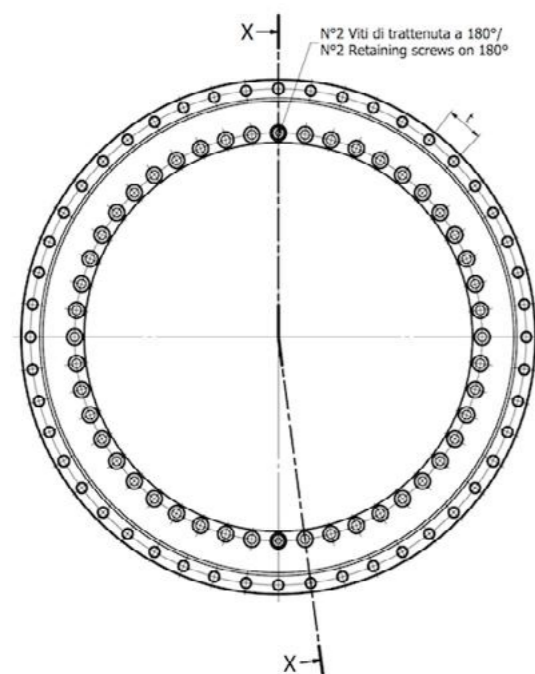

Code	OVERALL DIMENSIONS								FIXING HOLES Inner Ring			FIXING HOLES			PITCH			AXIAL LOAD RATING		RADIAL LOAD RATING		ng			
	d	D	H	H1	C	D1	J	J1	d1	d2	a	Q.ty.	d3	Q.ty.	Q.ty.	Q.ty.	t	Q.ty.	Ma	Dyn. [C]	Stat. [C]		Dyn. [C]	Stat. [C]	
	mm	mm	mm	mm	mm	mm	mm	mm	mm	mm	mm	#	mm	#	#		°	#	Kg	Nm	N	N	N	N	rpm
SEL/YAV0200	200	300	45	30	15	274	215	285	7	11	6,2	46	7	45	2	48	7,5	3	9	14	155000	840000	94000	226000	1200
SEL/YAV0260	260	385	55	36,5	18	345	280	365	9,3	15	8,2	34	9,3	33	2	36	10	3	18	34	173000	1050000	110000	305000	950
SEL/YAV0325	325	450	60	40	20	415	342	430	9,3	15	8,2	34	9,3	33	2	36	10	3	25	34	191000	1260000	109000	320000	800
SEL/YAV0395	395	525	65	42,5	20	486	415	505	9,3	15	8,2	46	9,3	45	2	48	7,5	3	33	34	214000	1540000	121000	390000	700
SEL/YAV0460	460	600	70	46	22	560	482	580	9,3	15	8,2	46	9,3	45	2	48	7,5	3	45	34	221000	1690000	168000	570000	600

TECHNICAL CONTENTS SEL/Y

ASSEMBLY AND ADJACENT ELEMENTS

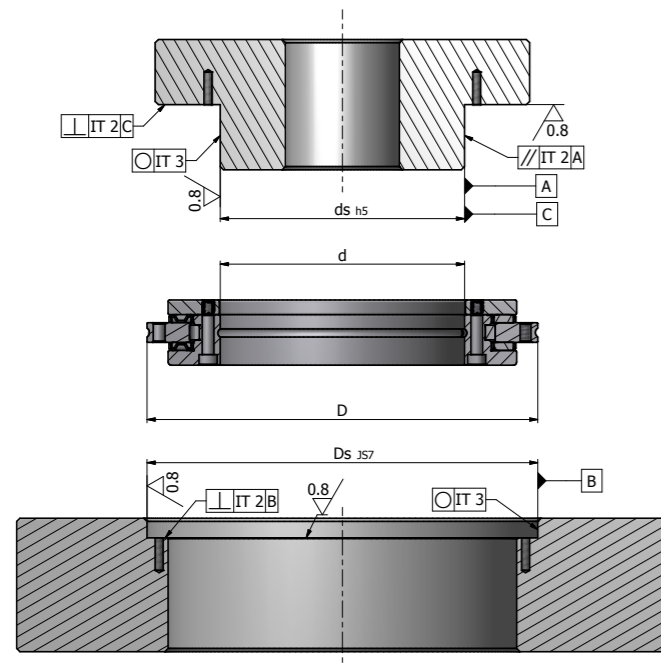

Code	D		d	
SEL/Y 050	126	-0,011	50	-0,008
SEL/Y 080	146	-0,011	80	-0,009
SEL/Y 100	185	-0,015	100	-0,01
SEL/Y 120	210	-0,015	120	-0,01
SEL/Y 150	240	-0,015	150	-0,013
SEL/Y 180	280	-0,018	180	-0,013
SEL/Y 200	300	-0,018	200	-0,015
SEL/Y 260	385	-0,02	260	-0,018
SEL/Y 325	450	-0,023	325	-0,023
SEL/Y 395	525	-0,028	395	-0,023
SEL/Y 460	600	-0,028	460	-0,023
SEL/Y 580	750	-0,035	580	-0,025
SEL/Y 650	870	-0,05	650	-0,038
SEL/Y 850	1095	-0,063	850	-0,05
SEL/Y 950	1200	-0,063	950	-0,05

SEL/Y - STANDARD assembly

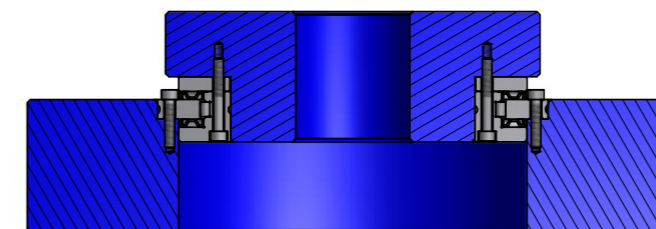

SEL/Y - VRI assembly

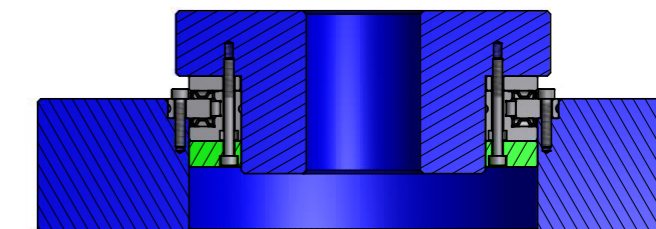

It is possible to use one more washer (not supplied) as support to the inner ring to increase the rigidity capacity of the bearing (assembly type VRI) – to be specified when ordering.

The bearings SEL/Y have to be assembled with screws having resistance class 10.9 through a torque wrench M_a (selected for each size). The screw tightening has to be carried out by crosswise sequence in three steps. This procedure will allow a self-balance of the tightening forces in the screws. The bearings series SEL/Y are supplied with two screws suitable for transport. These screws can be loosened during centering to make operations easier but they have to be tightened through wrench M_a (like the fixing screws) during final assembly.

ATTENTION: the bearings must not be dismantled! The screws used during transport must NEVER be completely loosened!

ATTENTION: incorrect screw assembly, in the inner ring especially, might cause wrong preload, thus compromising axial and radial run-out.

ATTENTION: if the assembly requires heating of the bearing or heating of the other components, please wait until the parts returned completely cold before starting working operations.

LI-BE recommends to get an easy coupling between the bearing and the construction to which it has to be screwed. Exception to this recommendation are the cases where a very precise positioning is required. A forced coupling might cause modification in the internal tensions.

If a very forced coupling is necessary, this condition should be clearly mentioned when ordering the parts.

The other elements which will be coupled with the bearings type SEL/Y have to guarantee and keep sufficient rigidity to prevent deformations due to coupling or screw assembly.

RIGIDITY

Rigidity is the capacity of a part to oppose the elastic deformation caused by a force applied on it. In short the formula is below, rigidity of a part= k is deformed to quantity δ because of applied force P :

$$k = P/\delta$$

The higher rigidity, the less will be the deformation borne when the part is subjected to the load.

Bearing SEL/Y is marked by high rigidity to tilting moments and to axial and radial forces. This capacity makes it the right choice in the working conditions where a high running precision is demanded when the load is applied.

Code	Kr	Ka	Kt
	[KN/ μ m]	[KN/ μ m]	[KNm/mrad]
SEL/Y 050	0,25	1,1	1,25
SEL/Y 080	0,5	1,8	2,5
SEL/Y 100	0,8	2	5
SEL/Y 120	1	2,2	7
SEL/Y 150	1,5	2,6	11
SEL/Y 180	2,2	3	17
SEL/Y 200	3	3,5	23
SEL/Y 260	5,5	4,5	45
SEL/Y 325	8,5	5	80
SEL/Y 395	12,5	6	130
SEL/Y 460	18	7	200
SEL/Y 580	30	9	380
SEL/Y 650	45	10	550
SEL/Y 850	80	13	1100
SEL/Y 950	100	14	1500

FRictionAL

Frictional torque M_{RL} shows the resistance to be won to keep the bearing rotation and it depends on more factors:

- Running speed
- Type and quantity of lubricant
- Pre-load
- Load applied

For this reason, the value M_{RL} has to be considered purely an indication and referred to an even rotation of 5 RPM at grease lubrication.

The starting torque or the torque at a different RPM could be slightly higher than reported.

The use of an additional washer for the inner ring (execution VRI) makes an increase of the frictional torque unavoidable.

Code	M_{RL}
	[Nm]
SEL/Y 050	2,5
SEL/Y 080	3
SEL/Y 100	3
SEL/Y 120	7
SEL/Y 150	13
SEL/Y 180	14
SEL/Y 200	15
SEL/Y 260	25
SEL/Y 325	48
SEL/Y 395	55
SEL/Y 460	70
SEL/Y 580	140
SEL/Y 650	200
SEL/Y 850	300
SEL/Y 950	600

LUBRICANT

Bearings type SEL/Y are supplied with grease DIN 51825 **KP2N-30** with mineral oil base and able to bear temperatures range -30/+140 °C

The bearing can be relubricated through the holes in the inner and outer rings.

LI-BE guarantees that the bearings are supplied with the correct quantity of lubricant. However we recommend to carry out a few rotations of the bearing while it is fixed without load to permit the correct distribution of the lubricant before putting it into use.

ATTENTION: too much lubricant can have consequences on the resistance to rotation MRL and on temperature production. In cases of overlubrication, please contact LI-BE engineering department.

TOLERANCES – AXIAL AND RADIAL RUNOUT

Code	H1	axial/radial runout
	±[mm]	[µm]
SEL/Y 050	0,125	2
SEL/Y 080	0,15	3
SEL/Y 100	0,175	3
SEL/Y 120	0,175	3
SEL/Y 150	0,175	3
SEL/Y 180	0,175	4
SEL/Y 200	0,175	4
SEL/Y 260	0,2	6
SEL/Y 325	0,2	6
SEL/Y 395	0,2	6
SEL/Y 460	0,225	6
SEL/Y 580	0,25	10
SEL/Y 650	0,25	10
SEL/Y 850	0,3	12

ATTENTION: values related to completely fixed bearings

EXECUTIONS WITH RESTRICTED TOLERANCES

LI-BE bearings series SEL/Y can be requested with:

- Running tolerances (planarity and run-out) restricted 50% : suffix **...RI**
- Reduced dimensional tolerance H1 : suffix **...HIR**
- Reduced dimensional tolerances H1 and H2 : suffix **...HIH2R**

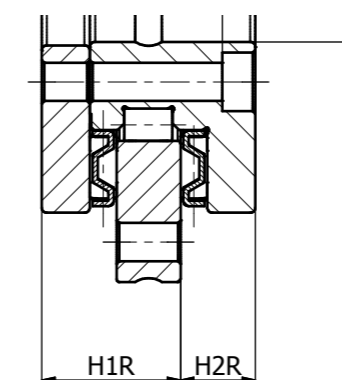

ATTENTION: values related to completely fixed bearings.

Example of order: 1 bearing SEL/Y inner diameter 150 mm, reduced tolerances H1 and H2 and with restricted running tolerances will have following LI-BE designation:

SEL/Y150.HIH2R.RI

Code	H1	H2	axial/radial runout
	±[mm]	±[mm]	[µm]
SEL/Y 050	0,025	0,02	1
SEL/Y 080	0,025	0,02	1,5
SEL/Y 100	0,025	0,02	1,5
SEL/Y 120	0,025	0,02	1,5
SEL/Y 150	0,03	0,02	1,5
SEL/Y 180	0,03	0,025	2
SEL/Y 200	0,03	0,025	2
SEL/Y 260	0,04	0,025	3
SEL/Y 325	0,05	0,025	3
SEL/Y 395	0,05	0,025	3
SEL/Y 460	0,06	0,03	3
SEL/Y 580	0,075	0,03	5
SEL/Y 650	0,1	0,03	5
SEL/Y 850	0,12	0,03	6
SEL/Y 950	0,12	0,06	6

TECHNICAL CONTENTS

ROLLER BEARINGS FOR SCREW DRIVE

MOUNTING FORCES

Individual bearing components are matched to each other and self retaining. The inner rings must not be removed during mounting and dismounting.

If components are removed from the bearing, please contact LI-BE before any reassembly.

During the mounting of bearings, mounting forces should be applied only to the bearing ring:

mounting forces can't be through the rolling elements or sealing rings.

FIXING SCREW

Screws of grade 10.9 should be used. Screws must be tightened with appropriate torque, in accordance with manufacturer's instructions and in a crosswise sequence.

LUBRICATION

Bearings for screw drives can be lubricated with grease or oil.

Mean bearing temperature should not exceed +50 °C. In this case, a lubrication method without heat dissipation such as grease lubrication or oil impulse lubrication can be selected. This is the most common case in machine tool systems.

The re-lubrication intervals are essentially based on the operating conditions and the environmental (such as temperature, contamination, dust, water, etc.) and can't be pre- determined. Bearings must always be re-lubricated after long stops.

DESIGN OF ADJACENT CONSTRUCTION

Adjacent construction must be designed following the data in the dimension tables.

The diameters for the shaft and housing shoulders d_o and D_o can be found in the bearing tables.

FRICTION

The frictional torque M_{RL}^* is a guide value. It is based on lightly oiled bearings, measured at a speed of $n = 5 \text{ min}^{-1}$ on dedicated test rig.

The drive should be dimensioned according these values:

Starting M_{RL}	$1,8 \cdot M_{RL}$
High Speed M_{RL}	$2,7 \cdot M_{RL}$

SPEEDS

The limiting speeds n_o given in the dimension tables are based on the following conditions:

- bearing preloaded, no external operating load
- operating duration 25%
- maximum equilibrium temperature +50°C

The limiting speeds n_o are valid for oil lubrication with adequate cooling.

* You can ask your M_{RL} to our technical office.

TECHNICAL CONTENTS

BALL BEARINGS FOR SCREW DRIVE

FIXING SCREW AND LOCKNUT

Screws of grade 10.9 should be used. You must tighten the screws with appropriate torque, according to the manufacturer's instructions and in a crosswise sequence.

The necessary fixing torque (M_a) must be used for the locknuts, according to the manufacturer calculations. Only use lock nuts with a good radial runout accuracy of the end face to the thread.

SETTLEMENT

In order to counteract settling, the following tightening sequence must be observed:

- tighten the precision locknut to twice the tightening torque M_a (or at 1.5x t)
- relieve the load again
- tighten the precision locknut to the stated tightening torque M_a
- secure the precision locknut against rotation by the torque controlled tightening of the grub screws

FRICTION

The frictional torque M_{RL} is a guide value. It is based on lightly oiled bearings, measured at a speed of $n = 5 \text{ min}^{-1}$ on a dedicated test rig.

The drive should be dimensioned according these values:

Starting M_{RL}	$1,8 \cdot M_{RL}$
High Speed M_{RL}	$2,7 \cdot M_{RL}$

In axial angular contact ball bearings with contact seals, the extent of seal friction cannot be disregarded. Sealing influences the limiting speeds and the heating of the bearing.

LUBRICATION

The relubrication intervals cannot be determined precisely in advance. They are essentially dependent on the operating conditions and the environmental influences such as temperature, contamination, dust, water, etc.

Bearings must always be relubricated:

- before and after long stoppage periods
- in conditions of high humidity
- within the defined lubrication intervals as stated in the technical proposal letter

For the following conditions, please contact us:

- stationary bearings
- vibrations
- very small oscillating movements

PRELOAD

The bearing rings are matched to each other: in this way a defined preload is achieved when the rings are fixed in place by a locknut.

After the preloading the bearing is axially clearance-free and its performance is assured.

NEVER replace or swap the rings or the rolling elements of the bearing; this makes the bearing itself unusable.

Preloading increases the stiffness of the bearing, assuring precise positioning of your Screw Drives even when heavily loaded.

Code	Stiffness	M _{RL} - 2RS	M _{RL} - 2Z	Pretension Load
	N/mm	Nm	Nm	N
SEL/N 010034	330	0,124	0,062	470
SEL/N 012042	390	0,166	0,083	775
SEL/F 012055	390	0,166	0,083	775
SEL/N 015045	415	0,207	0,103	755
SEL/F 015060	415	0,207	0,103	755
SEL/N 017047	460	0,248	0,124	831
SEL/N 017047.2AP	830	0,372	-	613
SEL/F 017062	460	0,248	0,124	831
SEL/F 017062.2AP	830	0,372	-	613
SEL/N 020052	670	0,310	0,155	1.497
SEL/N 020052.2AP	1.200	0,466	-	1.186
SEL/F 020068	670	0,310	0,155	1.497
SEL/F 020068.2AP	1.200	0,466	-	1.186
SEL/N 025057	770	0,414	0,207	1.727
SEL/N 025057.2AP	1.350	0,621	-	1.369
SEL/F 025075	770	0,414	0,207	1.727
SEL/F 025075.2AP	1.350	0,621	-	1.369
SEL/N 030062	875	0,517	0,259	1.958
SEL/N 030062.2AP	1.550	0,776	-	1.360
SEL/N 030072	945	0,828	0,414	3.671
SEL/F 030080	875	0,517	0,259	1.958
SEL/F 030080.2AP	1.550	0,776	-	1.360
SEL/F 030100	945	0,828	0,414	3.671
SEL/N 035072	950	0,621	0,310	2.233
SEL/N 035072.2AP	1.650	0,931	-	1.611

Code	Stiffness	M _{RL} - 2RS	M _{RL} - 2Z	Pretension Load
	N/mm	Nm	Nm	N
SEL/F 035090	950	0,621	0,310	2.233
SEL/F 035090.2AP	1.650	0,931	-	1.611
SEL/N 040075	1.050	0,724	0,362	2.538
SEL/N 040075.2AP	1.800	1,086	-	1.590
SEL/N 040090	1.220	1,345	0,672	5.054
SEL/F 040100	1.050	0,724	0,362	2.538
SEL/F 040100.2AP	1.800	1,086	-	1.590
SEL/F 040115	1.220	1,345	0,672	5.054
SEL/N 050090	1.295	0,931	0,466	3.103
SEL/N 050090.2AP	2.250	1,397	-	2.216
SEL/N 050110	1.440	2,690	1,345	6.070
SEL/F 050115	1.295	0,931	0,466	3.103
SEL/F 050115.2AP	2.250	1,397	-	2.216
SEL/F 050140	1.440	2,690	1,345	6.070
SEL/N 060110	1.340	-	1,035	3.685
SEL/F 060145	1.340	-	1,035	3.685
SEL/N 070120	1.500	-	1,241	4.095
SEL/F 070155	1.500	-	1,241	4.095
SEL/N 080130	1.650	-	1,448	4.505
SEL/F 080165	1.650	-	1,448	4.505
SEL/N 090150	1.750	-	2,379	4.505
SEL/F 090190	1.750	-	2,379	4.505
SEL/N 100160	1.950	-	2,690	5.729
SEL/F 100200	1.950	-	2,690	5.729
SEL/F 100230 ***	2.500	-	3,104	8.293

CUSTOM PRELOAD

The best preload for a system should be individually determined based on a bearings size and the system's required stiffness, life, and loading parameters.

Excessive preload can cause increased heat, fatigue, and torque.

Insufficient preload can allow poor positioning for the screw drives and also resonant vibration, causing fretting of the raceways.

LI-BE is able to calculate the specific preload that can fit the axial loads on your Screw Drive, optimizing rigidity and lifetime.

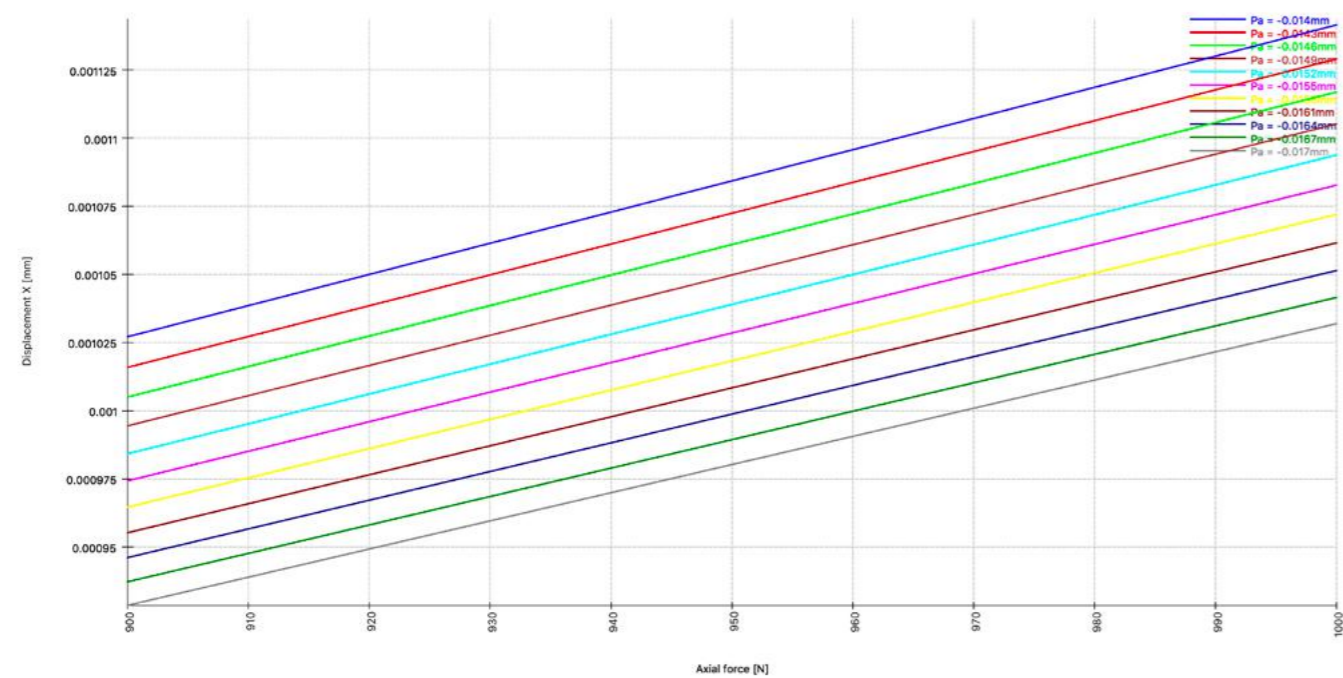

QUALITY CHECK

SEL LINE bearings are tested in a dedicated office.

100% SEL line bearings preload is tested by our technicians with custom testing devices to assure the best quality.

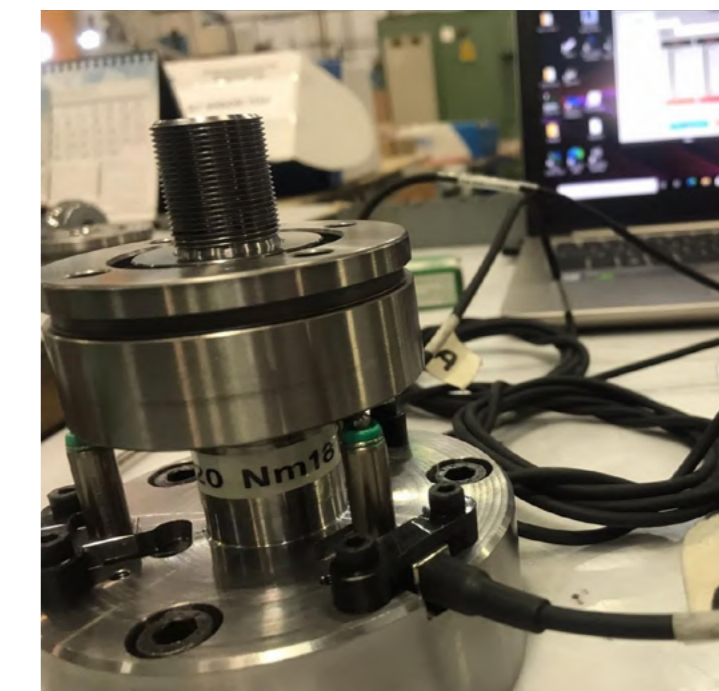

CONTACT US

LI-BE S.r.l.

S.S. 10 - Loc. Fabbrica, 46
27040 - Arena Po (PV), Italy

T: +39 0385 272419

F: +39 0385 272478 - 272072

E: info@li-be.com



www.li-be.com